

Pulse

JET PUMP FOR WELL KICK-OFF
DURING PRODUCTION AND
GEOPHYSICAL SURVEYS

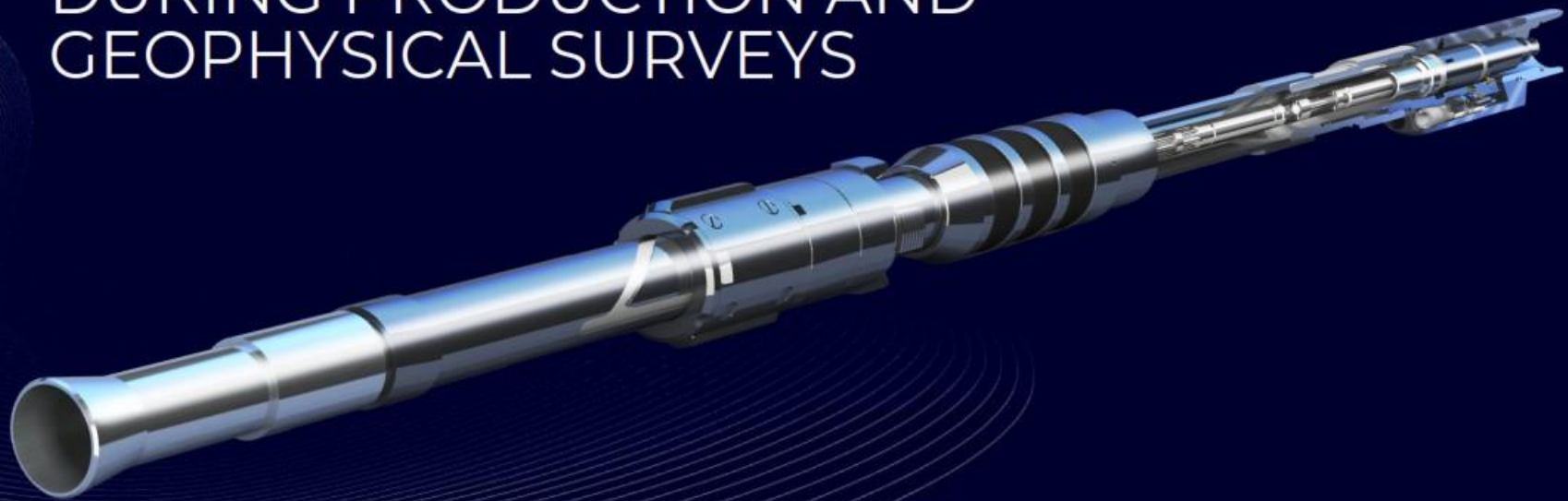

JET PUMP CONFIGURATION

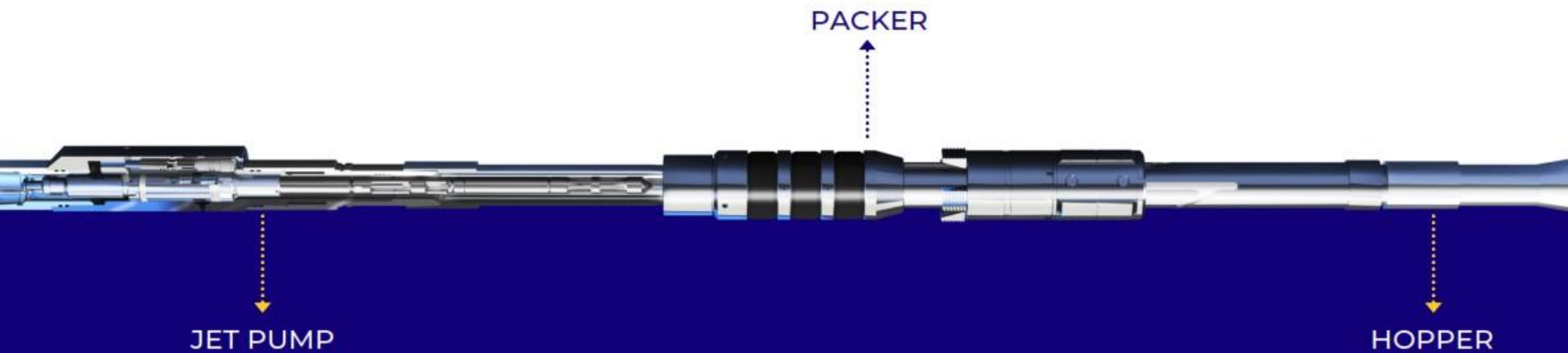

Pulse — jet pump for creating formation differential pressure during production and geophysical surveys

OPERATIONAL APPLICATION

1

CONDUCTING GEOPHYSICAL SURVEYS AT SPECIFIED DIFFERENTIAL PRESSURES

2

DEVELOPMENT AND CLEANING OF WELLS AFTER HYDRAULIC FRACKING, ACID BOTTOM-HOLE TREATMENTS OR DRILLING

3

IMPACT OF INSTANTANEOUS CYCLIC DIFFERENTIAL PRESSURES ON THE FORMATION



Pulse

Main technological advantages

- 1 FLOW PROFILE REGISTRATION IN WELLS WITH LOW FORMATION PRESSURE ($H_{stat} \leq 5900$ FT)
- 2 NO NEGATIVE IMPACT ON THE PRODUCTION CASING
- 3 NO LOST CIRCULATION OF THE FLUID
- 4 RECORDING FLOW-TIME PROFILE OVER A WIDE RANGE

Well parameters for Pulse

- Production casing diameter from 5,75 in
- Maximum load on the geophysical cable when extracting the inserts - up to 4410 lbf

3000

3000 psi —
maximum pressure of
working fluid

250

250 m³/day —
maximum flow
rate of Jet pump

13 100

13 100 ft —
maximum run depth

84

84 hours of operating
time at maximum
mode until it fails

Pulse Horizon

JET PUMP FOR WELL KICK-OFF
DURING PRODUCTION AND
GEOPHYSICAL SURVEYS



JET PUMP CONFIGURATION

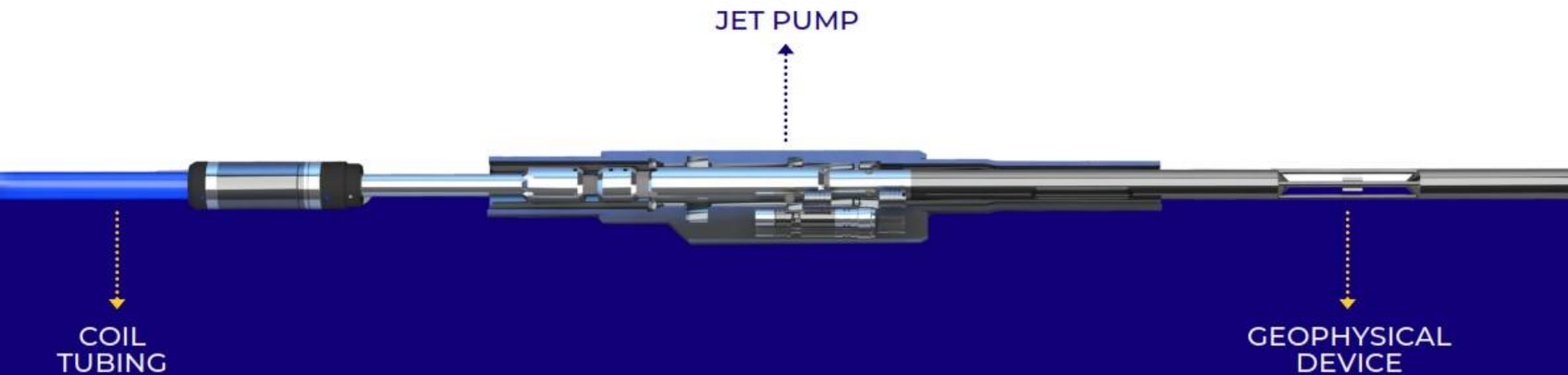

Pulse Horzont — jet pump for differential formation pressure during production and geophysical surveys on coiled tubing in wells with horizontal completion

OPERATIONAL APPLICATIONS

1

CONDUCTING HYDRODYNAMIC SURVEYS

2

CONDUCTING GEOPHYSICAL SURVEYS AT SPECIFIED DIFFERENTIAL PRESSURES

3

RETURN TO THE SURFACE OF THE REACTION PRODUCTS



Pulse Horizontal

Main technological advantages

- 1 ABILITY TO WORK WITH FLOW RATES ≤ 420 M³/DAY
- 2 FLOW-TIME PROFILE RECORDING AT A WIDE RANGE OF DIFFERENTIAL PRESSURES
- 3 PRODUCTION PROFILE RECORDING IN WELLS WITH LOW FORMATION PRESSURE ($H_{STAT} \leq 4920$ FT)
- 4 REDUCTION OF SURVEY TIME
- 5 REDUCTION SURVEY COSTS